

# DC-max 22 S Graphite Brushes

## DC motor Ø22 mm

8/10 W 12.5 mNm 9000 rpm



maxon X drives

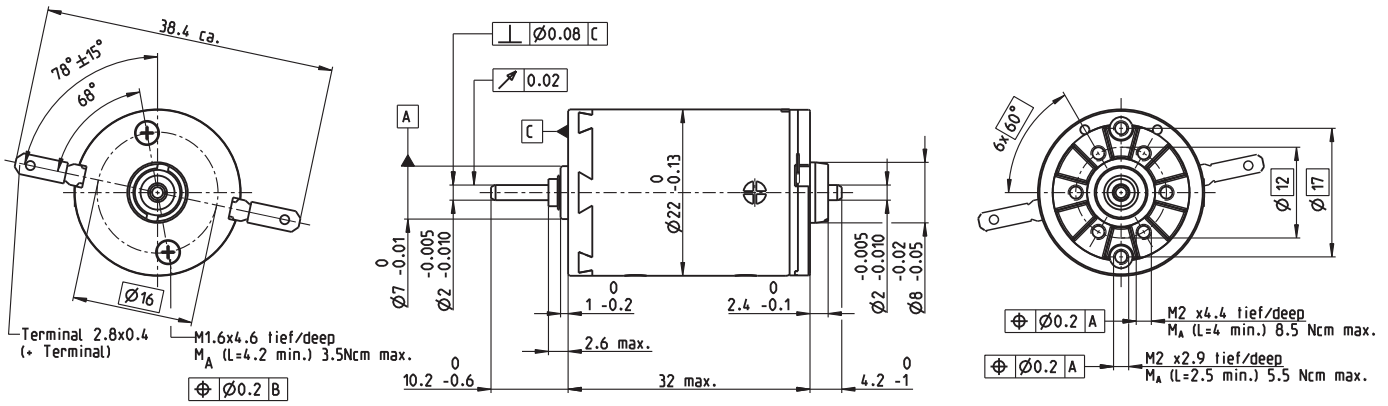

M 1:1

### Motor Data

1_	Nominal voltage	V	6	12	24
2_	No load speed	rpm	7030	7140	7330
3_	No load current	mA	58.8	29.5	15.1
4_	Nominal speed	rpm	4980	5260	5350
5_	Nominal torque (max. continuous torque)	mNm	11.3	12.5	11.8
6_	Nominal current (max. continuous current)	A	1.49	0.818	0.397
7_	Stall torque	mNm	42.4	49.4	44.6
8_	Stall current	A	5.39	3.14	1.45
9_	Max. efficiency	%	76	80	80
10_	Terminal resistance	Ω	1.11	3.83	16.6
11_	Terminal inductance	mH	0.069	0.274	1.05
12_	Torque constant	mNm/A	7.88	15.8	30.8
13_	Speed constant	rpm/V	1210	606	310
14_	Speed/torque gradient	rpm/mNm	171	147	167
15_	Mechanical time constant	ms	9.09	8.57	8.20
16_	Rotor inertia	gcm <sup>2</sup>	5.07	5.57	4.69

### Thermal data

17_	Thermal resistance housing-ambient	K/W	20
18_	Thermal resistance winding-housing	K/W	6
19_	Thermal time constant winding	s	16.8
20_	Thermal time constant motor	s	538
21_	Ambient temperature	°C	-30...85
22_	Max. winding temperature	°C	125

### Operating Range

n [rpm] Winding 12 V

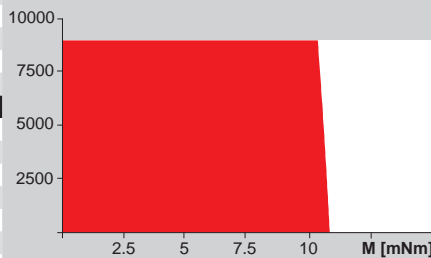

■ Continuous operation  
■ Continuous operation with reduced thermal resistance R<sub>th2</sub> 50%  
■ Intermittent operation

### Mechanical data ball bearings

23_	Max. speed	rpm	9000
24_	Axial play	mm	0.05...0.15
	Preload	N	0
25_	Radial play	mm	0.025
26_	Max. axial load (dynamic)	N	3.3
27_	Max. force for press fits (static) (static, shaft supported)	N	45
		N	420
28_	Max. radial load [mm from flange]	N	12.3 [5]

### Mechanical data sleeve bearings

23_	Max. speed	rpm	9000
24_	Axial play	mm	0.05...0.15
	Preload	N	0
25_	Radial play	mm	0.012
26_	Max. axial load (dynamic)	N	1
27_	Max. force for press fits (static) (static, shaft supported)	N	80
		N	420
28_	Max. radial load [mm from flange]	N	2.8 [5]

### maxon Modular System

<b>maxon gear</b>	Stages	<b>maxon sensor</b>	<b>maxon motor control</b>
130_GPX 22 A/C	1-2	146_ENX 10 QUAD	416_ESCON Module 24/2
131_GPX 22 LN/LZ	1-2	146_ENX 10 EASY	416_ESCON 36/2 DC
134_GPX 26 A/C	3		424_EPOS2 24/2 (DC/EC)
135_GPX 26 LN/LZ	3		424_EPOS2 Module 36/2
			435_MAXPOS 50/5

### Other specifications

29_	Number of pole pairs		1
30_	Number of commutator segments		9
31_	Weight of motor	g	53.8

### Configuration

Bearing: Sleeve bearings/ball bearings  
 Commutation: Precious metal brushes with CLL/Graphite Brushes  
 Shaft front/back: Length  
 Electric connection: Terminals/cable